

Force Engineering & Testing

19530 Ramblewood Drive
Humble, Texas 77338
Phone: (281) 540-6603 FAX: (281) 540-9966
Website: www.forceengineeringtesting.com

Product Evaluation Report
SUNSHINE METAL SUPPLY, INC.

1 1/2" Snap Lock, 24 Ga. Roof Panel over Plywood

Florida Product Approval # 18386.4 R2

Florida Building Code 2020
Per Rule 61G20-3
Method: 1 -D

Category: Roofing
Subcategory: Metal Roofing
Compliance Method: 61G20-3.005(1)(d)
HVHZ

Product Manufacturer:
Sunshine Metal Supply, Inc.
719 Cattleman Road
Sarasota, Florida 34232

Engineer Evaluator:
Johnathan Green, P.E. #88223
Florida Evaluation ANE ID: 12901

Validator:
Brian Jaks P.E. #70159

Contents:
Evaluation Report Pages 1 – 4

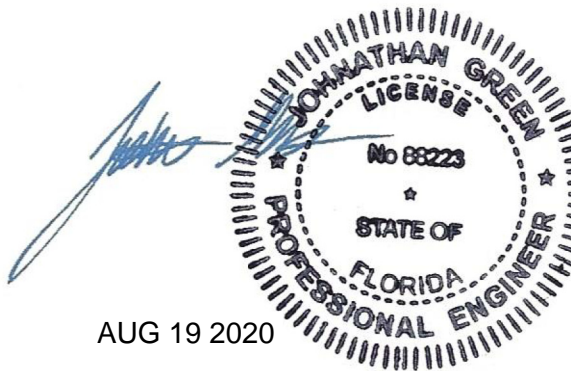

THIS ITEM HAS BEEN DIGITALLY SIGNED AND SEALED BY JOHNATHAN GREEN ON THE DATE ADJACENT TO THE SEAL.

PRINTED COPIES OF THIS DOCUMENT ARE NOT CONSIDERED SIGNED AND SEALED AND THE SIGNATURE MUST BE VERIFIED ON ANY ELECTRONIC COPIES.

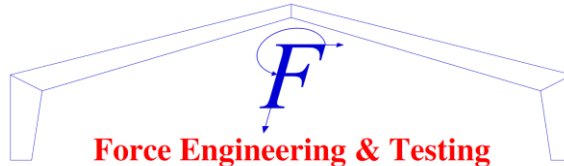

Force Engineering & Testing

19530 Ramblewood Drive
Humble, Texas 77338

Phone: (281) 540-6603 FAX: (281) 540-9966
Website: www.forceengineeringtesting.com

- Compliance Statement:** The product as described in this report has demonstrated compliance with the Florida Building Code 2020, Sections 1504.3.2, 1518.9, 1523.6.5.2.4.
- Product Description:** 1-1/2" Snap Lock Standing Seam Roof Panel, 24 Ga. Steel, 16" Wide, Roof Panel restrained with steel slider clips into APA Plywood decking. Non-structural Application.
- Panel Material/Standards:** Material: 24 Ga. Steel, ASTM A792 unpainted or painted with Valspar Fluropon or ASTM A653 G90 conforming to Florida Building Code 2020 Section 1507.4.3. Yield Strength: Min. 50.0 ksi
Corrosion Resistance: Panel Material shall comply with Florida Building Code 2020, Section 1507.4.3
- Panel Dimension(s):** Thickness: 0.024"
Width: 16" max coverage
Rib Height: 1-1/2"
Panel Seam: Snap Lock
- Roof Panel Clips:** Product Name: 1500SNS
Type: Fixed, 18 Ga., 3 1/2" long
Corrosion Resistance: Per Florida Building Code 2020 Section 1506.7
- Roof Clip Fastener:** (2) #12-11 Pancake Type A
1/4" minimum penetration through plywood
Corrosion Resistance: Per Florida Building Code 2020, Section 1517.6.
- Substrate Description:** 1) For HVHZ construction, use 19/32" or greater APA Rated plywood or wood plank. In reroofing applications where the deck is less than 19/32" thick (min. 15/32") the attachment of the decking in no case shall be less than 8D annual ring shank nails at 6" O.C. Design of plywood and plywood supports are outside the scope of this evaluation. Substrate must be designed in accordance w/ Florida Building Code 2020.
- 2) For Non-HVHZ applications, use min. 15/32" thick, APA Rated plywood over supports at maximum 24" O.C. Design of plywood and plywood supports are outside the scope of this evaluation. Substrate must be designed in accordance w/ Florida Building Code 2020.



AUG 19 2020

THIS ITEM HAS BEEN DIGITALLY SIGNED AND SEALED BY JOHNATHAN GREEN ON THE DATE ADJACENT TO THE SEAL.

PRINTED COPIES OF THIS DOCUMENT ARE NOT CONSIDERED SIGNED AND SEALED AND THE SIGNATURE MUST BE VERIFIED ON ANY ELECTRONIC COPIES.

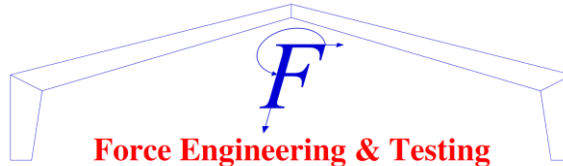

Force Engineering & Testing

19530 Ramblewood Drive
Humble, Texas 77338
Phone: (281) 540-6603 FAX: (281) 540-9966
Website: www.forceengineeringtesting.com

Allowable Design Uplift Pressures:

Table "A"

Maximum Total Uplift Design Pressure:	86.0 psf	108.5 psf	116.0 psf
Clip Spacing:	24" O.C.	12" O.C.	6" O.C.
# Fasteners per Clip:	2	2	2

*Design Pressure includes a Safety Factor = 2.0.

Code Compliance:

The product described herein has demonstrated compliance with The Florida Building Code 2020, Section 1504.3.2, 1518.9, 1523.6.5.2.4.

Evaluation Report Scope:

The product evaluation is limited to compliance with the structural wind load requirements of the Florida Building Code 2020, as relates to Rule 61G20-3.

Performance Standards:

The product described herein has demonstrated compliance with:

- TAS 125-03
- UL 580-06 - Test for Uplift Resistance of Roof Assemblies
- UL 1897-2012 - Uplift Test for Roof Covering Systems
- TAS 100-95 - Test Procedure for Wind and Wind Driven Rain Resistance of Discontinuous Roof Systems
- TAS 110-00 - Accel. Weathering ASTM G 155 / Salt Spray ASTM B 117

Reference Data:

1. TAS 125-03: UL 580-94 / 1897-98 Uplift Test
Force Engineering & Testing, Inc. (FBC Organization # TST-5328)
Report No. 72-0108T-07*
2. TAS 100-95
Farabaugh Engineering & Testing, Inc. (FBC Organization # TST-1654)
Report No. T107-07*
3. TAS 110-00: Valspar Fluropon coated metal panel testing
A) ASTM G 155
B) ASTM B 117
4. Certificate of Independence
By Johnathan Green, P.E. (No. 88223) @ Force Engineering & Testing
(FBC Organization # ANE ID: 12901)



THIS ITEM HAS BEEN DIGITALLY SIGNED AND SEALED BY JOHNATHAN GREEN ON THE DATE ADJACENT TO THE SEAL.

PRINTED COPIES OF THIS DOCUMENT ARE NOT CONSIDERED SIGNED AND SEALED AND THE SIGNATURE MUST BE VERIFIED ON ANY ELECTRONIC COPIES.

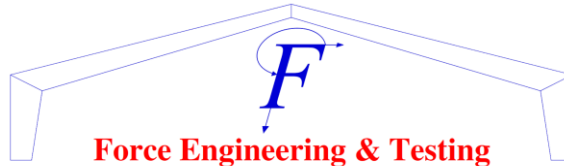

Force Engineering & Testing

19530 Ramblewood Drive
Humble, Texas 77338

Phone: (281) 540-6603 FAX: (281) 540-9966
Website: www.forceengineeringtesting.com

Test Standard Equivalency:

1. The UL 580-94 test standard is equivalent to the UL 580-06 test standard.
2. The UL 1897-98 test standard is equivalent to the UL 1897-2012 test standard.

Quality Assurance Entity:

The manufacturer has established compliance of roof panel products in accordance with the Florida Building Code and Rule 61G20-3.005 (3) for manufacturing under a quality assurance program audited by an approved quality assurance entity.

Minimum Slope Range:

2:12. Minimum Slope shall comply with Florida Building Code 2020, including Sections 1515.2.2 and in accordance with Manufacturers recommendations.

Installation:

Install per manufacturer's recommended details and RAS 133.

Underlayment:

Per Manufacturer's installation guidelines per Florida Building Code 2020 Section 1518.2, 1518.3, 1518.4.

Fire Barrier:

Any approved fire barrier having a current NOA. Refer to a current fire directory listing for fire ratings of this roofing system assembly as well as the location of the fire barrier within the assembly. Fire classification is not part of this acceptance.

Shear Diaphragm:

Shear diaphragm values are outside the scope of this report.

Design Procedure:

Based on the dimensions of the structure, appropriate wind loads are determined using Chapter 16 of the Florida Building Code 2020 for roof cladding wind loads. These component wind loads for roof cladding are compared to the allowable pressure listed above. The design professional shall select the appropriate erection details to reference in his drawings for proper fastener attachment to his structure and analyze the panel fasteners for pullout and pullover. Support framing must be in compliance with Florida Building Code 2020 Chapter 22 for steel, Chapter 23 for wood and Chapter 16 for structural loading.

*The Test Reports are owned by Metalforming, Inc. Metalforming, Inc. gives the above manufacturer permission to use these test reports.

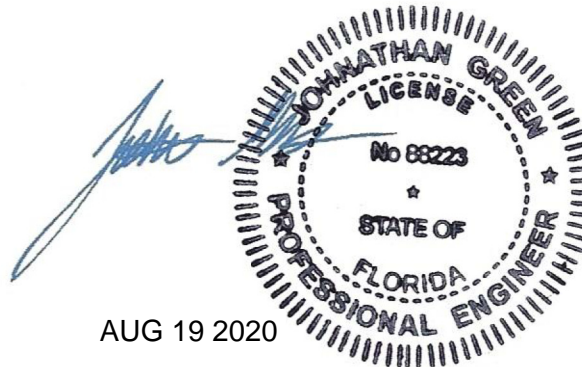

THIS ITEM HAS BEEN
DIGITALLY SIGNED AND
SEALED BY JOHNATHAN
GREEN ON THE DATE
ADJACENT TO THE SEAL.

PRINTED COPIES OF THIS
DOCUMENT ARE NOT
CONSIDERED SIGNED AND
SEALED AND THE
SIGNATURE MUST BE
VERIFIED ON ANY
ELECTRONIC COPIES.

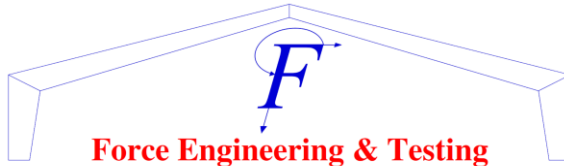

Force Engineering & Testing

19530 Ramblewood Drive
Humble, Texas 77338

Phone: (281) 540-6603 FAX: (281) 540-9966
Website: www.forceengineeringtesting.com

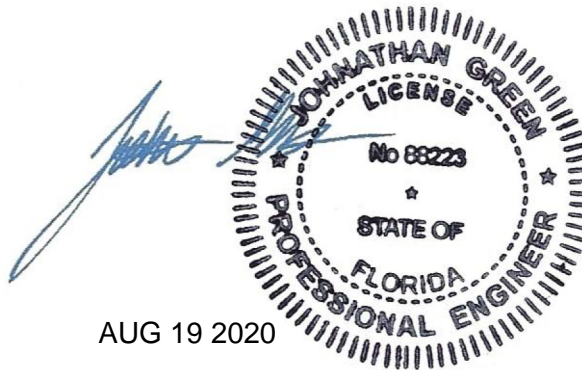
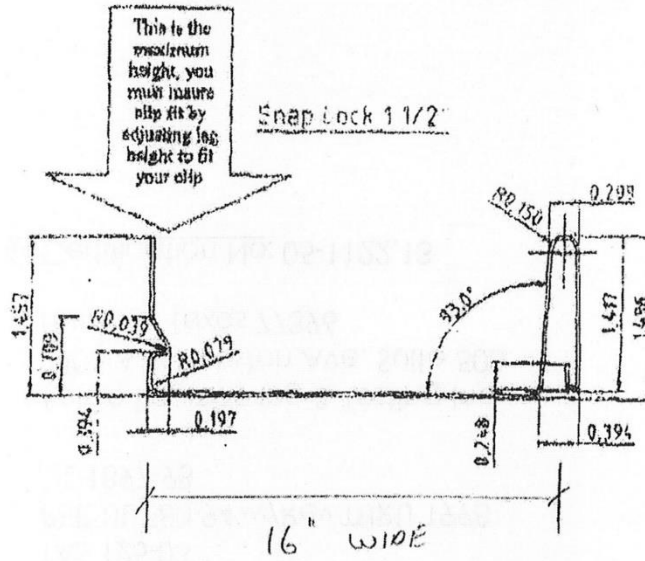

THIS ITEM HAS BEEN DIGITALLY SIGNED AND SEALED BY JOHNATHAN GREEN ON THE DATE ADJACENT TO THE SEAL.

PRINTED COPIES OF THIS DOCUMENT ARE NOT CONSIDERED SIGNED AND SEALED AND THE SIGNATURE MUST BE VERIFIED ON ANY ELECTRONIC COPIES.

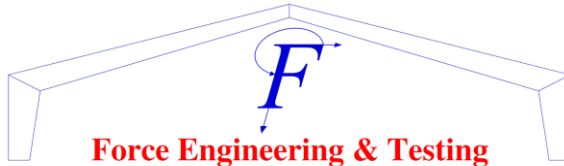

Force Engineering & Testing

19530 Ramblewood Drive
Humble, Texas 77338

Phone: (281) 540-6603 FAX: (281) 540-9966
Website: www.forceengineeringtesting.com

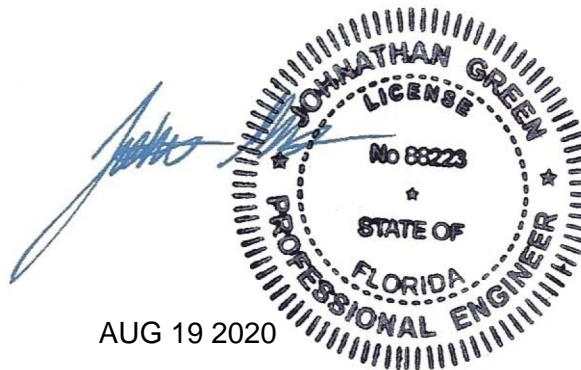
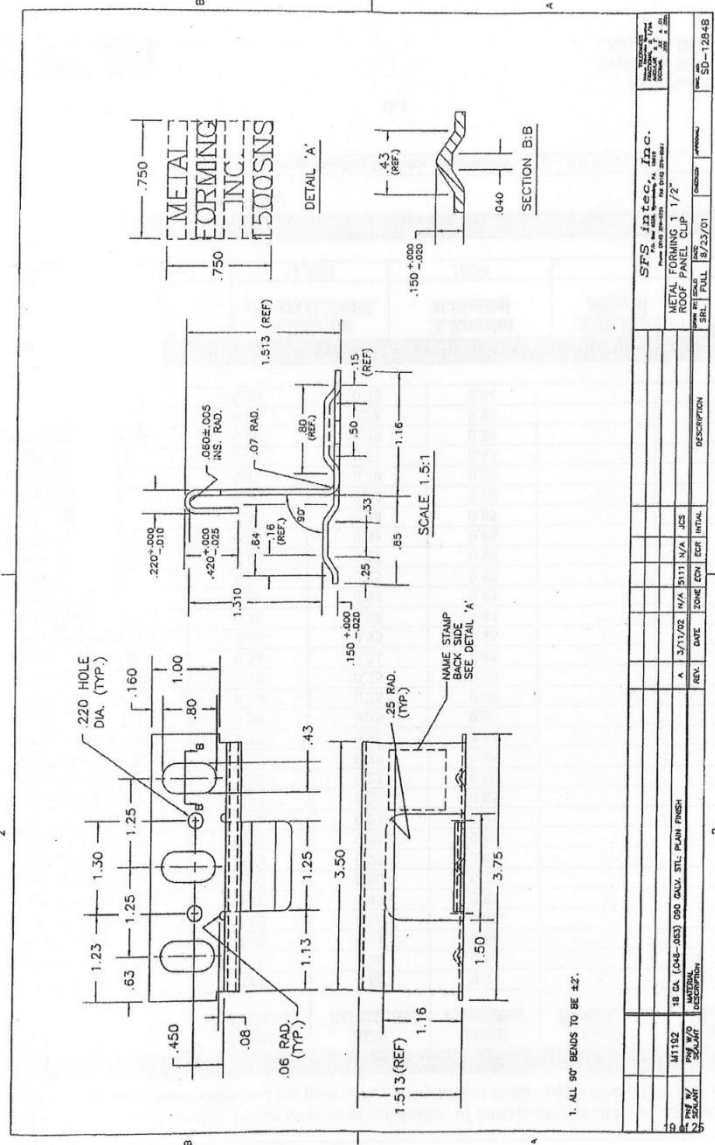

THIS ITEM HAS BEEN DIGITALLY SIGNED AND SEALED BY JOHNATHAN GREEN ON THE DATE ADJACENT TO THE SEAL.

PRINTED COPIES OF THIS DOCUMENT ARE NOT CONSIDERED SIGNED AND SEALED AND THE SIGNATURE MUST BE VERIFIED ON ANY ELECTRONIC COPIES.

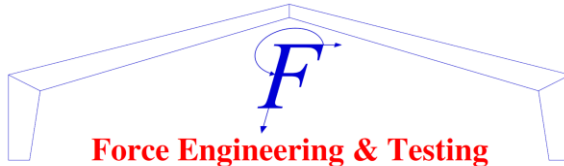

Force Engineering & Testing

19530 Ramblewood Drive
Humble, Texas 77338

Phone: (281) 540-6603 FAX: (281) 540-9966
Website: www.forceengineeringtesting.com

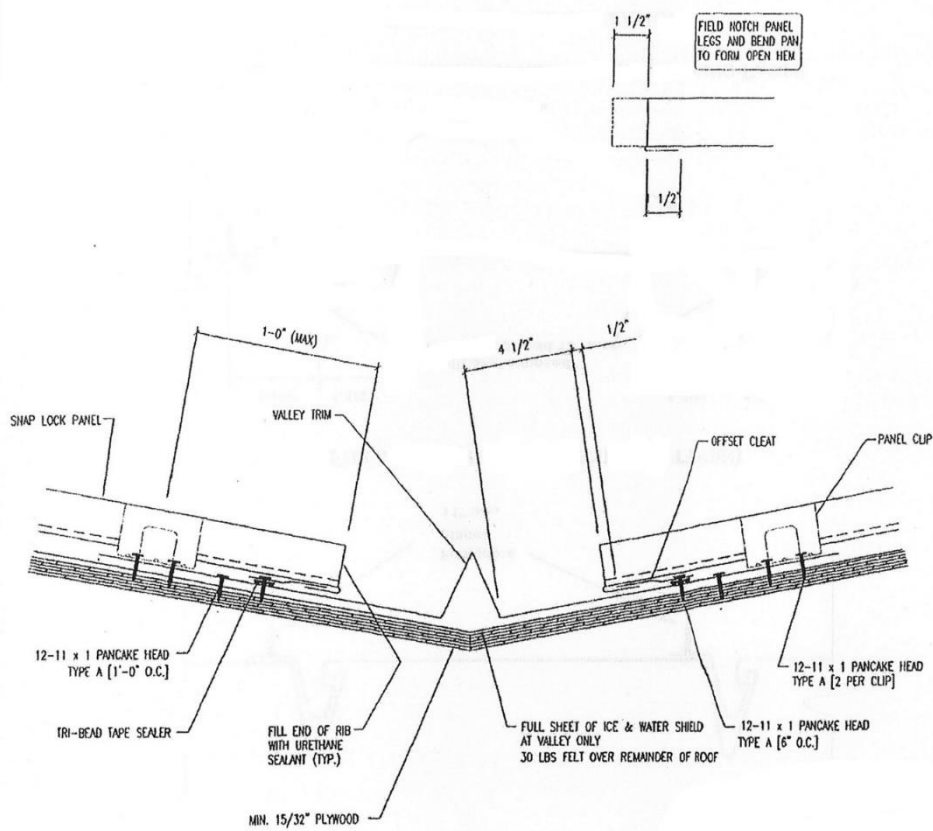

FLOATING VALLEY



THIS ITEM HAS BEEN DIGITALLY SIGNED AND SEALED BY JOHNATHAN GREEN ON THE DATE ADJACENT TO THE SEAL.

PRINTED COPIES OF THIS DOCUMENT ARE NOT CONSIDERED SIGNED AND SEALED AND THE SIGNATURE MUST BE VERIFIED ON ANY ELECTRONIC COPIES.

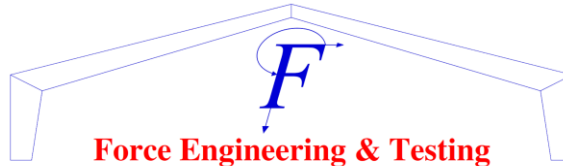

Force Engineering & Testing

19530 Ramblewood Drive
Humble, Texas 77338

Phone: (281) 540-6603 FAX: (281) 540-9966
Website: www.forceengineeringtesting.com

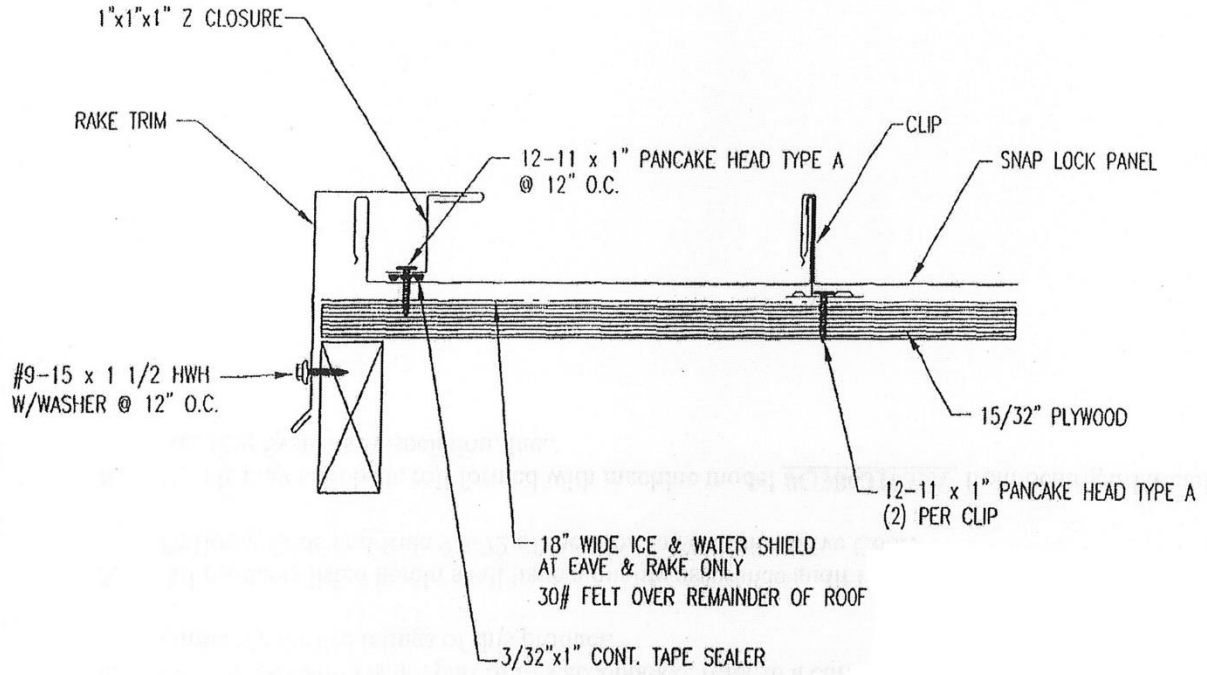

FIXED RAKE

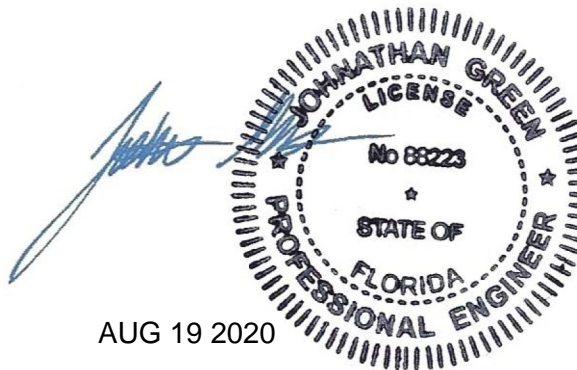

THIS ITEM HAS BEEN DIGITALLY SIGNED AND SEALED BY JOHNATHAN GREEN ON THE DATE ADJACENT TO THE SEAL.

PRINTED COPIES OF THIS DOCUMENT ARE NOT CONSIDERED SIGNED AND SEALED AND THE SIGNATURE MUST BE VERIFIED ON ANY ELECTRONIC COPIES.

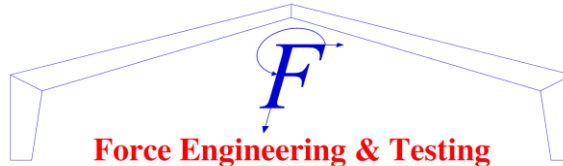

Force Engineering & Testing

19530 Ramblewood Drive
Humble, Texas 77338
Phone: (281) 540-6603 FAX: (281) 540-9966
Website: www.forceengineeringtesting.com

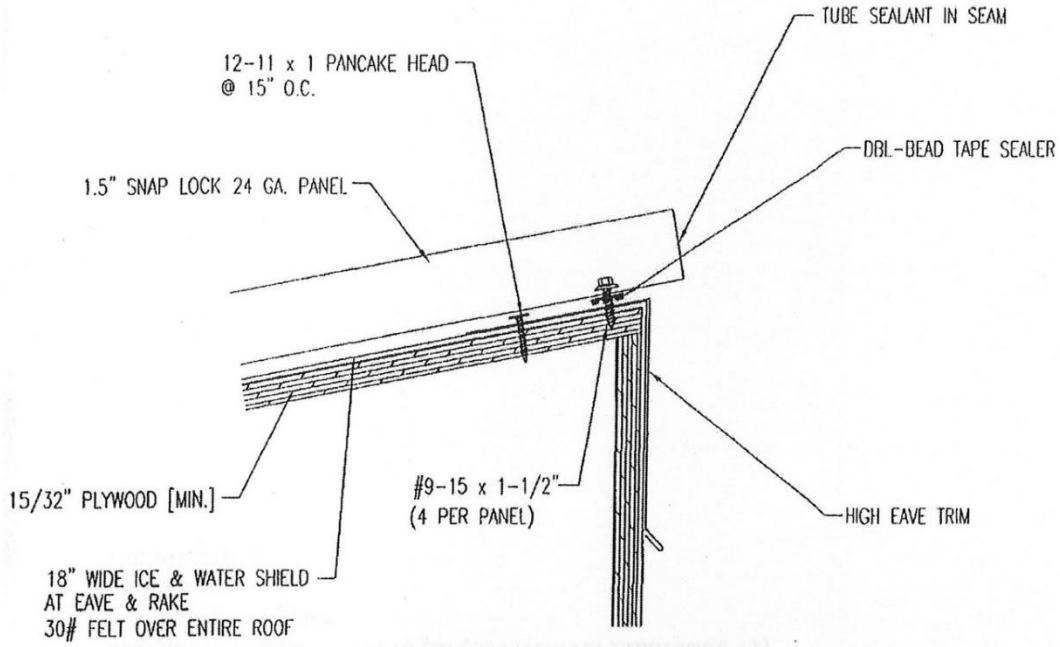

HIGH EAVE DETAIL



THIS ITEM HAS BEEN DIGITALLY SIGNED AND SEALED BY JOHNATHAN GREEN ON THE DATE ADJACENT TO THE SEAL.

PRINTED COPIES OF THIS DOCUMENT ARE NOT CONSIDERED SIGNED AND SEALED AND THE SIGNATURE MUST BE VERIFIED ON ANY ELECTRONIC COPIES.